

# Site Set-up - Standard



## **Purpose**

To select and set up a Carbon Cycle Sample Site to be assessed for aboveground carbon storage.

## **Overview**

Students will develop and improve skills necessary for field site set up and measurement, including pacing and how to use a compass. They will complete the set up of a Carbon Cycle Sample Site.

## **Student Outcomes**

Students will be able to:

- Use pacing to measure distance.
- Use a compass to orient a field plot.
- Use a GPS to mark plot center.
- Use new skills to set up a Carbon Cycle Sample Site.

## **Questions**

- How much carbon is being stored in the trees near my school?
- Is there more carbon in the global population or the vegetation of \_\_\_\_\_?
- How does carbon uptake in our schoolyard compare to carbon emissions from our school? (*at least 2 years worth of data needed*)

## **Science Concepts**

Grades 9-12

### **Scientific Inquiry**

- Design and conduct a scientific investigation
- Use appropriate tools and techniques to gather, analyze, and interpret data
- Use mathematics in all aspects of scientific inquiry

### NGSS

#### **Science and Engineering Practices**

- Planning and carrying out investigations
- Using mathematics and computational thinking

## **Level**

Secondary (Middle & High School)

## **Time**

- 45 minutes skills practice
- 90 minutes Site Set-up

## **Frequency**

Only needs to be conducted once for each sample site.

## **Prerequisites**

If your school or class has already established a Landcover Sample Site, there is no need to establish a new site for Carbon Cycle measurements (skip the main part of the activity and see *Appendix: Discussion Points Site Visit - Years 2+ below*).

## **Materials and Tools**

- Pencil (1/student)
- Science notebook (1/student)
- Compass (1/student pair)
- Flexible measuring tape (30-50m) (1-2/class)
- Digital camera or smartphone
- GPS or smartphone with GPS capabilities
- Local field guide OR MUC Field Guide
- Student Site Set-up Packet:
  - *Compass and Pacing Instructions*
  - *Sample Site Student Instructions*
  - *Site Set-up Data Sheet*
  - *GPS Investigation Data Sheet* (if using a GPS receiver)

## **Preparation**

If you are new to student field excursions read *Appendix: Taking Students Outside*, which discusses considerations to make before heading to the field, including: weather, insects, appropriate clothing, etc.)

Go over important information with students at least one day before going out to the field site.



## Background

Students can now put basic concepts learned during engagement activities into practice. Carbon dioxide is taken up by trees during photosynthesis and is stored as carbon in the roots, bark, branches, stem and leaves. Carbon, the building block of life, accounts for approximately 45-50% of the mass of all living things after the water has been removed. While perhaps the best way to find the exact mass of each tree under consideration is to cut it down, oven dry it and weigh it, this is neither practical nor logical. To this end scientists, including ecologists and foresters, have cut down many trees of varying sizes and varieties to come up with size based relationships, called allometry. One relationship that has proved especially consistent is between diameter at breast height and tree biomass. Such a consistent relationship led to the development of allometric equations that allow scientists, and now students, to measure circumference (or DBH) to estimate the biomass of whole trees as well as their individual components including leaves, branches, bark, stem and roots. With a good estimate of biomass, carbon storage of each

tree and its components can also be calculated. While carbon storage estimates of individual tree components are great for understanding ecosystem dynamics such as how the ratio of carbon in roots versus stem changes with a change in environmental conditions it can also be interesting to look at carbon storage at larger scales including a specific sample site, schoolyard, town or region. This type of scaling allows us to look at the bigger picture of carbon storage and provides a reference point to consider when making management decisions in the light of climate change. Should these trees be logged? Should more trees be planted? If the biomass of the same trees is then monitored over several years you can begin to look at growth, carbon uptake over time, another important component in the global carbon cycle equation. Carbon uptake from the atmosphere is particularly interesting because it is the opposite of carbon emissions to the atmosphere, typically calculated through a carbon footprint assessment.

---

## What To Do and How To Do It

### SITE SET-UP SKILLS

**Grouping:** Class or Small Groups

**Time:** 45 min

Before students can complete the Carbon Cycle Site Set-up they will need to gain skills in pacing and compass use (and optional: GPS use). While site set-up will not require all students to perform all skills, some skills, such as compass use, will be required for later Carbon Cycle activities or future field investigations.

### Pacing and How to Use a Compass

- Instruction sheets (below) are designed to be copied and provided for students OR to be used for giving verbal instructions to the entire student group.
- Activities can be completed indoors or outdoors.

### GPS Investigation

- A GPS (or smartphone with GPS capabilities) should be used to mark plot center. This will allow you to return to the exact center of your field plot each year, as well as allow you to view your site location on the GLOBE website or Google maps. If using a GPS receiver, use the *GLOBE GPS Protocol*.
- Depending on your time and teaching goals there are many options for obtaining GPS data on your site:
  - Collect the data yourself during site selection or site set up.
  - Show 2 students how to use the GPS/phone to collect data during site set-up.
  - Teach all students about GPS using the learning activities in the *GLOBE GPS Teacher Guide and Learning Activities* document. Select 2 students to collect data.

## SET-UP A SITE

**Grouping:** Class

**Time:** 90 min

- Gather field materials and tools.
- Divide your class into 3-4 teams to perform azimuth and pacing, take site photos and record data, and- if using a GPS recorder- 1 team of 2 students to take GPS measurements (if using a smartphone, the data recording team can record the GPS measurement). Additional students can begin to identify the site's land cover type and the local biome. Students may begin with a local field guide, use the MUC Field Guide: A Key to Land Cover Classification and GLOBE Landcover Biometry Protocol, or begin the GLOBE Seasons and Biomes: What is my Biome? Protocol.
- Students review their team's instructions
  - The Corner Team and Perimeter Team should use the *Student Field Guide*
  - The GPS Team should use the *Student Field: GPS Team and the GPS Investigation Data Sheet* (only if using a GPS receiver)
  - The Center Team should use the *Student Field Guide* and complete the *Site Set-up Data Sheet*.

### Assessment

Active participation in Sample Site Set-up.

### Adaptations

- Younger students are capable of completing all parts of the fieldwork, but may need additional time and teacher direction. For students ages 10 – 13, it is recommended to have additional adults at the field site.
- If you have students with mobility concerns you may consider placing your sample site next to a more accessible trail or close to the school building. Once in the sample site these students could act as the data recorder for their group.

### Extensions

- To complete the basic Carbon Cycle Sample Site Set-up students can simply follow the *Center Team Instructions*. If, however, you plan to use the sample site for additional studies, on topics such as plant phenology, seasons, succession, landcover change, or forest health, you

may consider installing a PicturePost. More information about the use, building, and installation of PicturePosts can be found at the Picture Post website: <http://picturepost.unh.edu>

- To gain a more complete understanding of carbon storage in the schoolyard (or surrounding area) set up multiple Carbon Cycle Sample Sites. Use the Landcover Classification Investigation as a method for determining how many and where additional sample sites should be located.

### Resources/References

- Using a Compass - <http://www.dnr.state.wi.us/org/caer/ce/cek/cool/orienteering.htm>
- Going Outside - Project Learning Tree's Resource Guide for Conducting a Forest Field Day
- Carbon Cycle eTraining: [www.globe.gov/get-trained/protocol-etaining/etraining-modules/16867717/3099387](http://www.globe.gov/get-trained/protocol-etaining/etraining-modules/16867717/3099387)

## APPENDIX

### Discussion Points Site Visit - Years 2+

Time: 30 minutes

After the initial year of participation in the GLOBE Carbon Cycle project, it will not be necessary for students to complete the Carbon Cycle Site Set-up activities or, if applicable, the Tree Mapping activities. You may, however, decide to set up an additional field site or re-map the existing site simply for students to get experience in measurement and mapping skills or to do comparison studies. Regardless of what you decide, it is still important for students to understand how the sample site was designed and measured before they collect the present year's data.

Below is one method for providing students basic site information.

1. Visit the sample site.
2. Students explore the sample site, making notes and diagrams in their science notebook about what they observe.
  - a. What is the shape of the sample site? How is it divided? How large is it?
  - b. Are there any flags, stakes, or markings? What do they represent?
  - c. What measurements have been taken? What tools might have been used?
  - d. What type of vegetation is present?
3. Students share observations. Provide any additional information (that students did not mention in their observations) about the basic procedure that was used to map and measure the site in previous years.
4. Discuss the basic field procedure students developed during the inquiry activity and how their ideas are similar or different to the methods used at the actual sample site.
5. If applicable: bring mapping tools and walk through how to add a "new" tree (a tree that has just reached 15cm circumference) to the *Tree Data Entry Sheet*.
6. Proceed with Carbon Cycle field measurement protocols (Tree Circumference, Shrubs/Saplings, Herbaceous Vegetation).

## Going Outside: Things you might face in the field

(Adapted from Project Learning Tree's Resource Guide for Conducting a Forest Field Day)

### Informing Parents and Principals

While it may not be necessary if you are not taking students off school property, informing parents and principals of your plans can be a good idea. When people understand why students are going outside they are often more supportive. They may even offer to lend a hand in the field or provide needed tools and resources.

If you plan to spend several class periods outside, consider providing parents with a brief explanation of the work students do and offer to be available for any questions (especially concerning the topics below)

### Carry a First-Aid Kit

- Bring a first aid kit stocked with band-aids, an ice pack, and latex gloves.
- Know the school's first aid policies and how to use the supplies.
- Bring and be familiar with emergency medicines required by your students, such as inhalers or bee sting kits.

### Check the Weather

- While scientists often have to complete field measurements regardless of the weather, one goal of the fieldwork is for students to be excited about and engaged in making scientific measurements. To best complete this goal it is better to avoid "bad" weather days. Extreme cold and precipitation will limit student attention and likely result in poor data collection.
- Depending on where you live insects including, mosquitoes, black flies, and ticks may also be a significant problem. Do a little research to find out what time of year these insects are most prevalent and do your best to avoid them. If you go out anyway, make sure students are prepared.
  - Check with local authorities to learn the best prevention methods for local insect borne diseases.
- Keep in mind that it is often possible to do some parts of the field activity in the classroom, which can minimize the outdoor component in the case of bad weather.

### Discuss Appropriate Clothing and Footwear

- Discuss with students what they think is appropriate for a fieldwork activity. How does "appropriate" change based on time of year,

weather and site conditions?

- You may want to check out the field site a day or two before students will visit so you can let them know the current conditions (mud, poisonous plants, snow).
- Make a class list of appropriate clothing based on the expected field conditions -
  - Shoes: sneakers or boots – no heels, sandals, or slip-ons
  - Cold weather: jackets, hats, gloves
  - Warm weather: pants and long sleeves are still recommended to protect from sun and insects
  - Sunscreen and/or insect repellent may be important if you plan to be out for longer periods of time
- Remind students that they will be more comfortable if they are reasonable in their clothing selections.
  - Students should know that if their lack of preparation poses a safety issue they will miss out on the fieldwork opportunity.

### Establish Expected Student Rules for Safety and Behavior (Field Ethics)

- Stay with the group – It is important in the event of an emergency.
- Don't run – To ensure everyone's safety.
- Stay on the trail – This helps protect the surrounding environment.
- Respect the environment – Do not pick plants, leaves, bark, etc.
- Leave animals alone – Do not try to pet or catch animals, for their safety and yours.
- Don't eat anything you find – Many berries and mushrooms look like something you know, but may in fact be toxic to humans.
- Remember you are in an outdoor classroom and all standard classroom rules apply
  - Be a good listener
  - Respect each other
  - Work together

### Prepare Students to be Successful

- Give each student a responsibility that is important to the project (GPS techy, equipment lacy, data recorder, etc.)
- Rehearse what you will do at the field site before going out

## Pacing

(Borrowed from GLOBE Biosphere Investigation Instruments)

A pace is equal to walking two steps. Knowing how long your pace is will be helpful during many GLOBE field investigations.

### Directions for Determining Pace

1. Record the pacing data table (shown below) into your science notebook.

Trial 1	Trial 2	Trial 3	Average Paces  =(trial 1+ trial 2 + trial 3)/ 3	Pace/ Meter  = (average/ 10m)	# of paces for 15 meters  = 15m x (pace/m)	# of paces for 21.2 meters  = 21.2m x (pace/m)	# of paces for 30 meters  = 30m x (pace/m)

2. Lay out a 10 meter or longer measuring tape on a flat, open area (e.g. a parking lot, field, or hallway).
3. Remember that one pace equals two steps. Starting with your toe at the 0 meter mark, pace off, using a normal, comfortable stride.
4. Count your paces until you reach 10 meters. Keep in mind you may have .5 paces (landing on your non-counted foot) or you may have .25 or .75 paces (landing in between your feet).
5. Record your number of paces in the pacing data table.
6. Repeat steps 2-4 two more times. Calculate your mean pace distance (by adding up the three lengths and dividing by three).
7. Now find your pace per meter by dividing your average paces by 10 meters.

### Determining the Number of Paces to Travel a Given Distance

Once you know your pace per meter and you know the distance you are trying to go (e.g. 30m the length of one side of a standard 30m x 30m sample site) you can calculate how many paces are needed.

# of paces needed = desired distance(m) \* # of paces/m

Possible desired distances:

- 30 meters (the side length of a sample site)
- 15 meters (the side length of a quadrant within a sample site)
- 21.2 meters (the length of the diagonal within a quadrant – measured from site center to any corner)

\*You could also lie out a 30m tape and simply count your number of paces for all the required distances (30, 21.2 and 15 meters). Be sure not to skip the step of repeating each measurement 3 times and finding an average.

**NOTES:** Pacing in the woods or over hilly terrain is quite different than pacing a flat distance in a schoolyard or parking area. Remember the following tips:

- When initially measuring your pace walk using a comfortable stride. Resist the temptation to take exaggerated steps because your pace will naturally become shorter in the woods or over hilly terrain.
- When pacing up or down a hill, you are actually traveling a shorter horizontal distance than it seems, and you may also pace irregularly due to the terrain. Be aware of your paces and compensate by taking slightly shorter or longer steps as necessary.
- When large objects (boulders, large trees, etc.) are in the way, take a few lateral side steps, pace forward, then take the same number of lateral side steps back to your original compass bearing (see figure). If an observation is required while side stepping and pacing around an obstacle then estimate the reading from the sidestepped position.
- If an object is too large to conveniently side step, stop at the object and send a team member out in front of the object (at least 10m) at the desired azimuth and have a team member stand where you are. Once they are both in place, walk around the object until you are directly in-line with your two team members. Estimate the number of paces taken up by the object and then start counting paces again heading toward your team member who is positioned at the correct azimuth.



# How to Use a Compass

(Adapted from GLOBE GPS Investigation, Wisconsin Department of Natural Resources Explorer Program, Environmental Education for Kids)

A compass is useful for many applications. In the case of GLOBE field investigations the compass will be used to set up field sites that can be measured and returned to every year.

## Investigating a Compass

1. Review the parts of the compass.
2. Examine the degrees noted on the housing of your compass. Degrees are typically in increments of  $2^\circ$  or  $5^\circ$ .
3. Hold the compass flat in the palm of your hand with the direction of travel arrow pointed away from you.
4. Practice turning the housing.
5. The red part of the magnetic needle points toward Earth's magnetic north pole.
6. Move slowly around the area, and watch how the needle always points the same direction.
  - a. It doesn't always point in the same direction? Is there any metal around? Jacket zippers, keys, field tools, desks – How do these objects effect the magnetic needle?

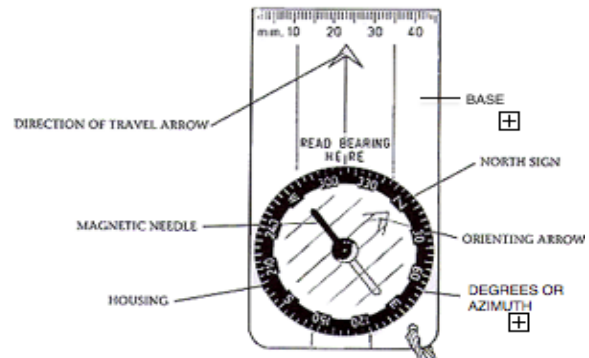

## Magnetic Declination

As you may know there are two North Poles on Earth. Magnetic North – where the compass points – is an area of highly magnetic rock under central Canada. True North is geographically at the top of the Earth ( $90^\circ$  N) – maps are based on True North. Declination is the angle between the two. The size and angle depends your location. Declination is important to navigating correctly and can also be important in orienting your sample site to satellite images. Compasses have either a mechanism to set the declination so it is accounted for in your compass reading or a scale to make the calculation yourself. (To find your local declination, see *GPS Investigation: World Magnetic Declination Map.*)

## Using a Compass

### Goal 1: Face North

- Hold your compass in front of you, turn the housing dial until the N is lined up with the direction of travel arrow – where it says, “Read bearing here”.
- Now turn your body, NOT YOUR COMPASS, until the red part of the magnetic needle is inside of the orienting arrow. A catchy way to remember this is – Red in the Shed
- You are now facing north. Practice again using E ( $90^\circ$ )

### Goal 2: Which direction are you facing?

- Turn your body to face a direction of your choice.
- Turn the housing until Red is in the Shed.
- Read the degrees that are lined up with the direction of travel arrow – this is the azimuth.

### Goal 3: Find the azimuth of an object

- Holding the compass correctly in your hand, select a nearby object and turn to face it.
- Turn the housing until Red is in the Shed.
- Read the azimuth – this is the direction to the object from where you are standing.

### Goal 4: Pace on an azimuth

- Turn your housing to the desired azimuth for pacing.
- Turn your body until Red is in the Shed.
- Choose an object (or partner) that is in line with your azimuth and pace toward it. This allows you to walk without looking down at your compass, thus creating a straighter path.



## Carbon Cycle Site Set-up - Student Field Guide

### Corner Team

1. Start at the center of the site.
2. Select one person to stand at center with the compass. Turn the housing to an azimuth of one of the sample site corners (e.g. 315°).
3. Instruct a second person to stand at the given azimuth some distance from the center. (This person will keep the pacer on the correct azimuth.)
4. The third group member should pace 21.2 meters along the azimuth toward the second person.
5. Place a temporary flag or stake at 21.2 meters. Each corner will be checked by the Perimeter team.
6. Repeat the process for the cardinal direction (e.g. North) to your right. Pacing only 15 meters before placing a flag. [These flags divide the sample site into 4 quadrants.]

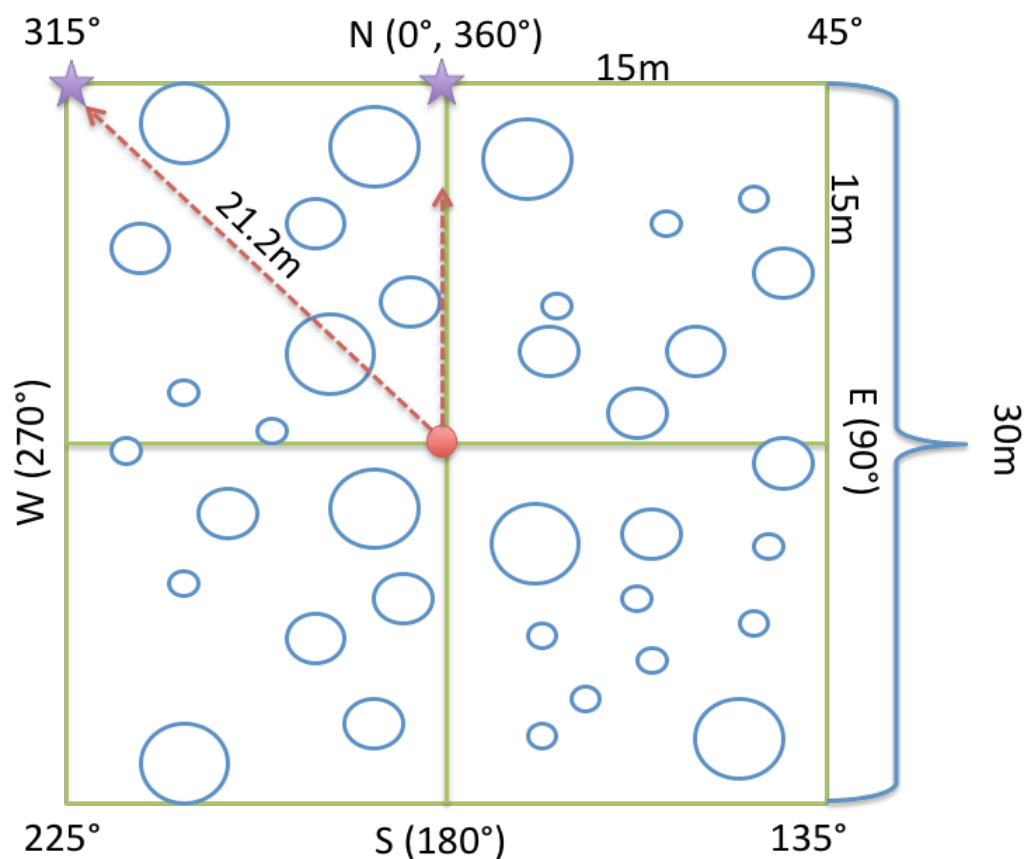

## Carbon Cycle Site Set-up - Student Field Guide

### Perimeter Team

1. Start at first corner of the site completed by a Corner Team.
2. Select one person to stand at the corner with the compass. Turn the housing to a cardinal direction (N, E, S, W), heading toward another sample site corner.
3. Instruct a second person to stand at the given azimuth some distance from the starting corner. (This person will keep the pacer on the correct azimuth.)
4. The third group member should pace 30 meters along the azimuth toward the second person.
5. Place a temporary flag or stake at 30 meters.
6. If the new flag is less than 3 meters from a Corner group's flag, keep the original flag and remove yours. If it is more than 3 meters leave your flag and have the Corner team re-pace that corner.
7. Repeat the process for all site corners.

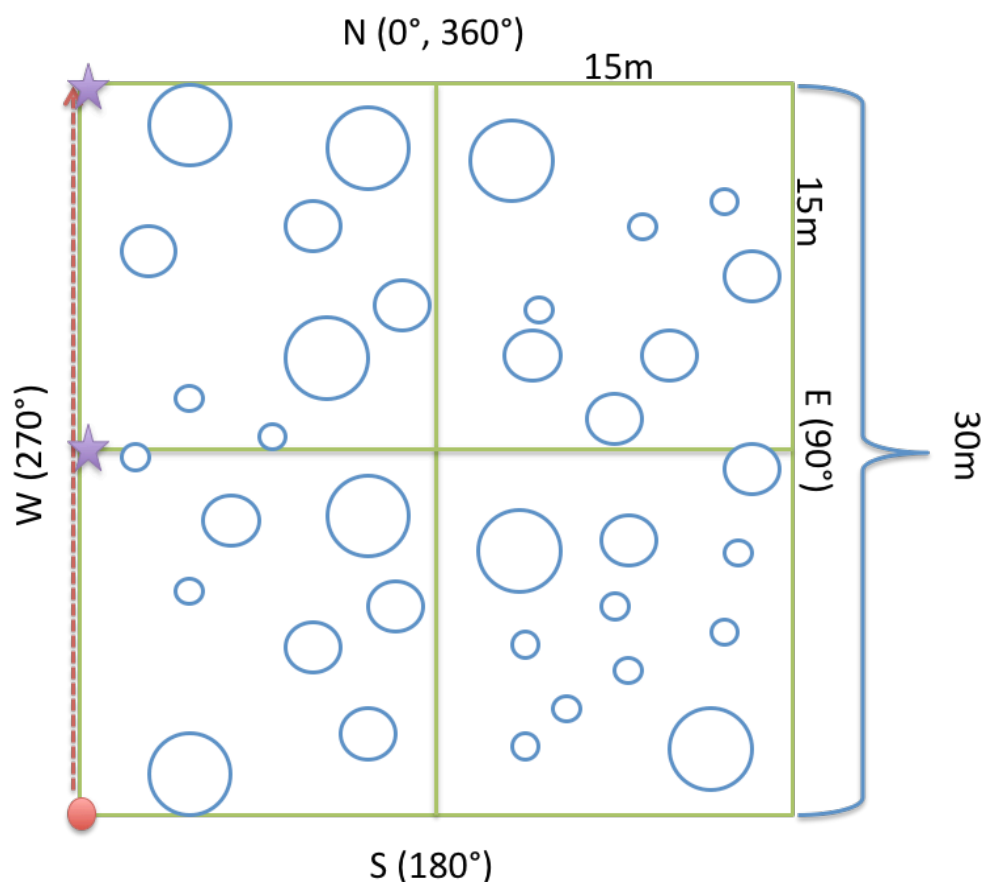

## Carbon Cycle Site Set-up - Student Field Guide

### Center Team

1. Stand at the site center.
2. Record the appropriate site location information on the *Site Set-up Data Sheet*.
3. To complete the vegetation analysis have each team member independently estimate percent cover of shrubs/saplings and herbaceous cover. Record all estimates on the *Site Set-up Data Sheet* and find the average. **Keep in mind that you will only measure the shrubs/saplings on your plot if they cover greater than 25% of the sample site area, and herbaceous vegetation if it covers more than 50%.**
4. To begin the photography measurements, check to make sure the date and time in the camera are correct.
5. Use a compass to orient your team and take one photo in each of 9 directions, the cardinal directions (N,S,E,W), their intermediates and up into the canopy.
6. Record the digital number of the photo for each of the photos taken on the *Site Set-up Data Sheet*, so you can identify them later.
7. If there is extra time, walk the sample site area and take other relevant photos, such as dead or downed trees (to note their change in decay from year to year), and other student teams performing site set-up tasks.

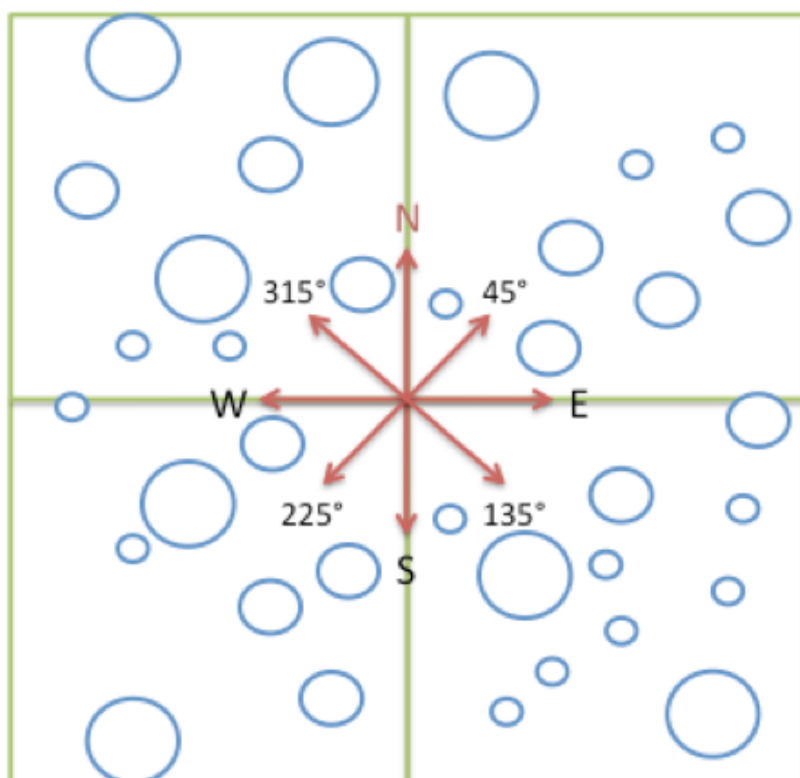

## Carbon Cycle Site Set-up - Student Field Guide

### GPS Team

#### Task

Measure the latitude, longitude, and elevation of your school or a GLOBE study site.

#### Materials

- GPS receiver
- Watch
- GPS Data Sheet
- Pen or pencil

#### Procedure

1. Take the GPS receiver to site center (or the exact location you would like to determine latitude, longitude, and elevation).
2. Turn on the receiver, making sure that you are holding it vertical and you are not blocking the antenna's view of the sky. In most receivers the antenna is internal and is located at the top of the receiver.
3. After an introduction message, the receiver will start to search for satellites. Some receivers may display the previous latitude, longitude, and elevation values while it is locking onto satellite signals.
4. Wait for the receiver to indicate that at least four satellites have been acquired and that a good measurement is available. In most receivers, this is indicated by the appearance of a "3-D" message.
5. At one minute intervals and without moving the receiver more than one meter, make five recordings on a copy of the GPS Investigation Data Sheet of all digits and symbols for the following displayed values:
  - a) Latitude
  - b) Longitude
  - c) Elevation
  - d) Time
  - e) Number of satellites
  - f) "2-D" or "3-D" status icons
6. Turn off the receiver.
7. Average all five latitudes, longitudes, and elevations.
8. Confirm for yourself that your results make sense. You should be able to get a rough estimate of your latitude and longitude by looking at a globe or local map.

# Carbon Cycle Site Set-up - Data Sheet

School Name: \_\_\_\_\_

Date/Time: \_\_\_\_\_  
 Year                      Month                      Day                                      Hour (local)                      Hour (UT)

Recorded By: \_\_\_\_\_

## SITE LOCATION

Site Type (circle all that apply):

Atmosphere    Carbon Cycle    Hydrology    Landcover    Pheology    Soil

Site Name: \_\_\_\_\_

City/State/Country: \_\_\_\_\_

Shape of Site:  Square     Rectangle     Circle     Other (sketch)

Site Dimensions (meters): \_\_\_\_\_

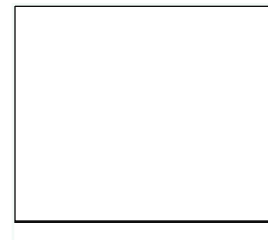

## SITE VEGETATION ASSESSMENT

Are there Trees (circle one)?    Yes            No

% Cover shrubs/sapling:    \_\_\_\_\_    \_\_\_\_\_    \_\_\_\_\_    \_\_\_\_\_    Average: \_\_\_\_\_  
    Team            Team            Team            Team  
    Member 1    Member 2    Member 3    Member 4

% Cover herbaceous:    \_\_\_\_\_    \_\_\_\_\_    \_\_\_\_\_    \_\_\_\_\_    Average: \_\_\_\_\_  
    Team            Team            Team            Team  
    Member 1    Member 2    Member 3    Member 4

## METADATA (Comments)

\_\_\_\_\_

\_\_\_\_\_

\_\_\_\_\_

\_\_\_\_\_

\_\_\_\_\_

## PHOTO NUMBER AND ORIENTATION FROM SITE CENTER

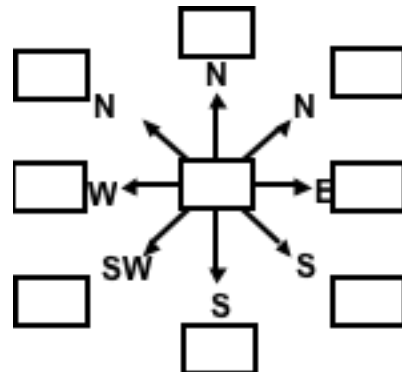

# GPS Investigation - Data Sheet

School Name: \_\_\_\_\_ Date: \_\_\_\_\_

Site Type (circle all that apply):

Atmosphere    Carbon Cycle    Hydrology    Landcover    Pheology    Soil

Site Name: \_\_\_\_\_

Recorded By: \_\_\_\_\_

- Do not begin recording data until GPS receiver has “locked in.”
- Wait at least one minute between recording observations.
- Record the following data form the appropriate screens on your GPS unit.

	Latitude Decimal degrees N/S	Longitude Decimal degrees E/W	Elevation (Meters)	Time H:M:S UTC	# Sats Satellites	Messages Circle if Shown
1						2D 3D
2						2D 3D
3						2D 3D
4						2D 3D
5						2D 3D

			← Averages
--	--	--	------------

## GPS Unit Information

Brand Name: \_\_\_\_\_

Model Number: \_\_\_\_\_